

1

2

3

TABLE 1

| SUB ASSEMBLY PART NO. AND CH. CODE | NO. | PART NO. AND CH. CODE | PART NAME | MATERIAL | COLOR | QTY. |
|---------------------------------------|-----|------------------------------------|-------------------------------------|----------|-------------|------|
| 7287-7976-6W ETC. (SEE TABLE 2) | ① | 7187-7976-60 ETC. (SEE TABLE 2) | SQUIB 2P HOUSING FEMALE (TYPE Y) | PBT | SEE TABLE 2 | 1 |
| | ② | 7173-1872 | SQUIB 2P SLIDER | PBT | NATURAL | 1 |
| | ③ | 7144-1800-0W | SQUIB 2P SPRING | STEEL | | 1 |

TABLE 2

| SUB ASSEMBLY PART NO. AND CH. CODE | PART NO. AND CH. CODE | COLOR |
|---------------------------------------|--------------------------|---------|
| 7287-7976-6W | 7187-7976-60 | GREEN |
| 7287-7976-0W | 7187-7976 | NATURAL |
| 7287-7976-7W | 7187-7976-70 | YELLOW |
| 7287-7976-8W | 7187-7976-80 | BROWN |
| 7287-7976-9W | 7187-7976-90 | BLUE |

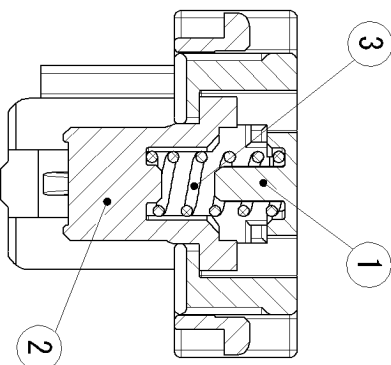
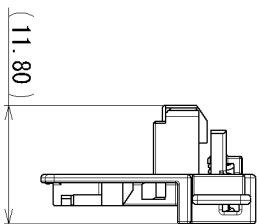
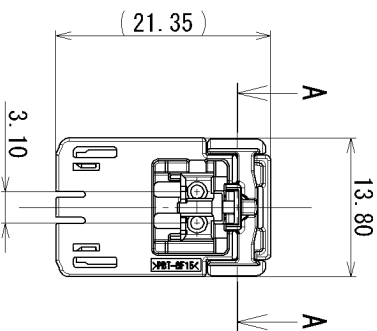
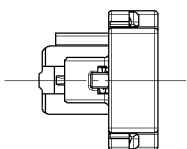

SEC. A-A(5:1)

注記

1. 対応相手品番 : 7272-0592-60 ETC.
2. 適用端子品番 : 7116-7118-08

NOTES

1. MATING PART NO. : 7272-0592-60 ETC.
2. APPLICABLE TERMINAL PART NO. : 7116-7118-08

| GENERAL TOLERANCE | | | | | | | | | |
|-------------------|--------|---------|---------|---------|--------|---------|---------|---------|-------|
| 10 MAX | 50 MAX | 100 MAX | 250 MAX | 250 OVR | RS MAX | R10 MAX | R20 MAX | R20 OVR | ANGLE |
| A ±0.15 | ±0.2 | ±0.3 | ±0.5 | ±0.75 | ±0.2 | ±0.3 | ±0.5 | ±2.5 | ±3° |
| B ±0.2 | ±0.3 | ±0.55 | ±0.95 | ±1.4 | ±0.2 | ±0.3 | ±0.5 | ±2.5 | ±3° |
| ③ ±0.3 | ±0.5 | ±0.8 | ±1.4 | ±2 | ±0.3 | ±0.5 | ±2.5 | ±3° | 0.15 |

MATL. SEE TABLE
SPEC. & FIN. TREAT. ISSUE MARK

NAME SQUIB 2P FEMALE SUB ASSEMBLY
(TYPE Y)

PART NO. 7287-7976-6W ETC.
CH. CODE

DWG NO. 7287-7976-6W:R SET DWG NO.

YAZAKI CORPORATION

| DATE | REVISION RECORD | NO. | CHKD |
|------------|-----------------|----------|------|
| 2012/03/29 | NEW | G12-Z354 | J B |

| CUSTOMER | CUSTOMER PART NO. | CUSTOMER DWG NO. |
|----------|-------------------|------------------|
| | | |

| OFFICE | TRIAL PART NO. |
|--------|----------------|
| J B | |

| GENERAL TOLERANCE | ANGLE | ECCENT |
|-------------------|-------|--------|
| 10MAX ±0.15 | ±0.3 | ±30° |
| 50MAX ±0.2 | ±0.3 | ±30° |
| 100MAX ±0.3 | ±0.55 | ±1.4 |
| 250MAX ±0.75 | ±1.4 | ±2 |
| 250OVR ±1.4 | ±2 | ±30° |

| LET | DATE | REVISION RECORD | NO. | CHKD |
|-----|------------|-----------------|----------|------|
| | 2012/03/29 | NEW | G12-Z354 | J B |

| DWG TYPE | DWG SOURCE | DWG DATE | UNIT | SCL | ANGLE |
|----------|------------|------------|------|-----|-------|
| R | NEW | 2012/03/29 | mm | 2:1 | 3 |

| APPROVED | CHECKED | CHECKED | DESIGN | DRAWN |
|-----------|-----------|---------|-----------|--------------|
| H. OHSUMI | K. OHTAKA | | K. OHTAKA | J. BONTI/GAO |

1

2

3

A

B

A

B