

7287-0492-40  
KEYWAY A

(2/1)

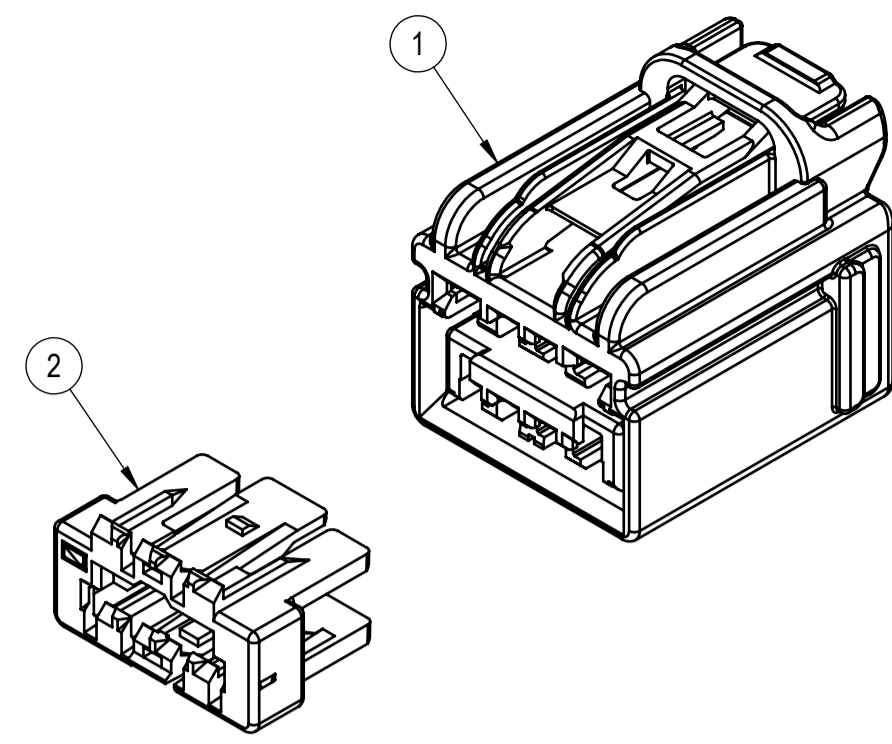

EXPLODED VIEW  
(2/1)

SUB-ASSEMBLY PART NUMBER	NO.	PART NUMBER	PART NAME	MATERIAL	COLOR	QUANTITY
7287-0492-40	①	7187-0492-40	8P (6Px1.5 + 2Px2.8) YESC KAIZEN UNSEALED FEMALE CONNECTOR HOUSING	PBT-GF15	LIGHT GRAY	1
	②	7158-6019-50	8P (6Px1.5 + 2Px2.8) YESC KAIZEN UNSEALED FEMALE CONNECTOR TPA	PBT	RED	1

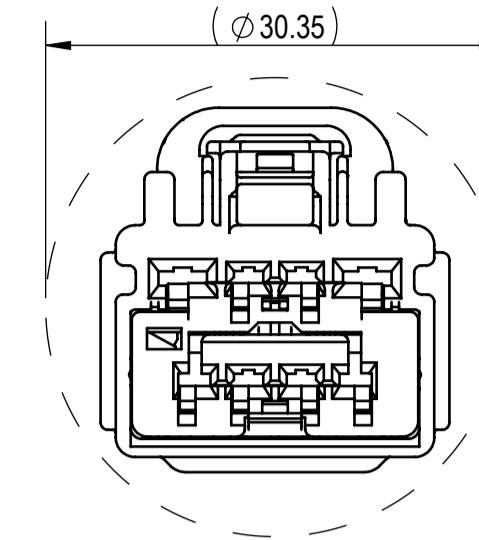

RECOMMENDED PASS-THROUGH  
HOLE DIMENSION  
(1mm CLEARANCE ALL AROUND)  
(2/1)

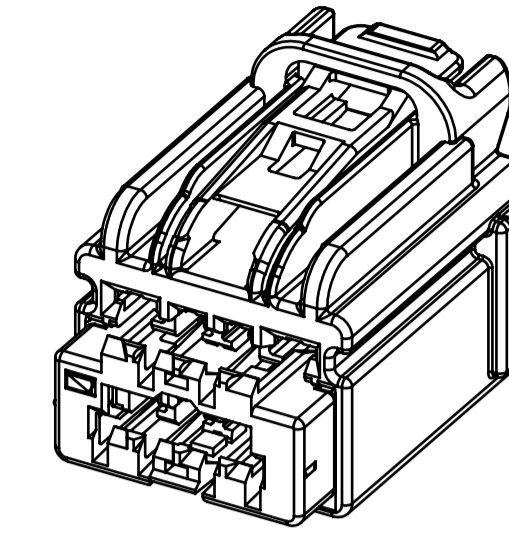

FRONT ISOMETRIC VIEW  
(2/1)

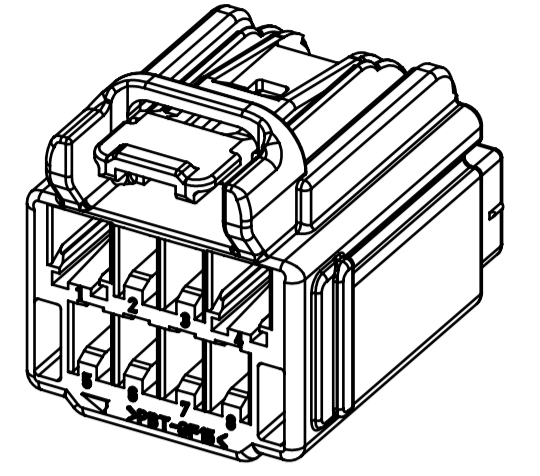

REAR ISOMETRIC VIEW  
(2/1)

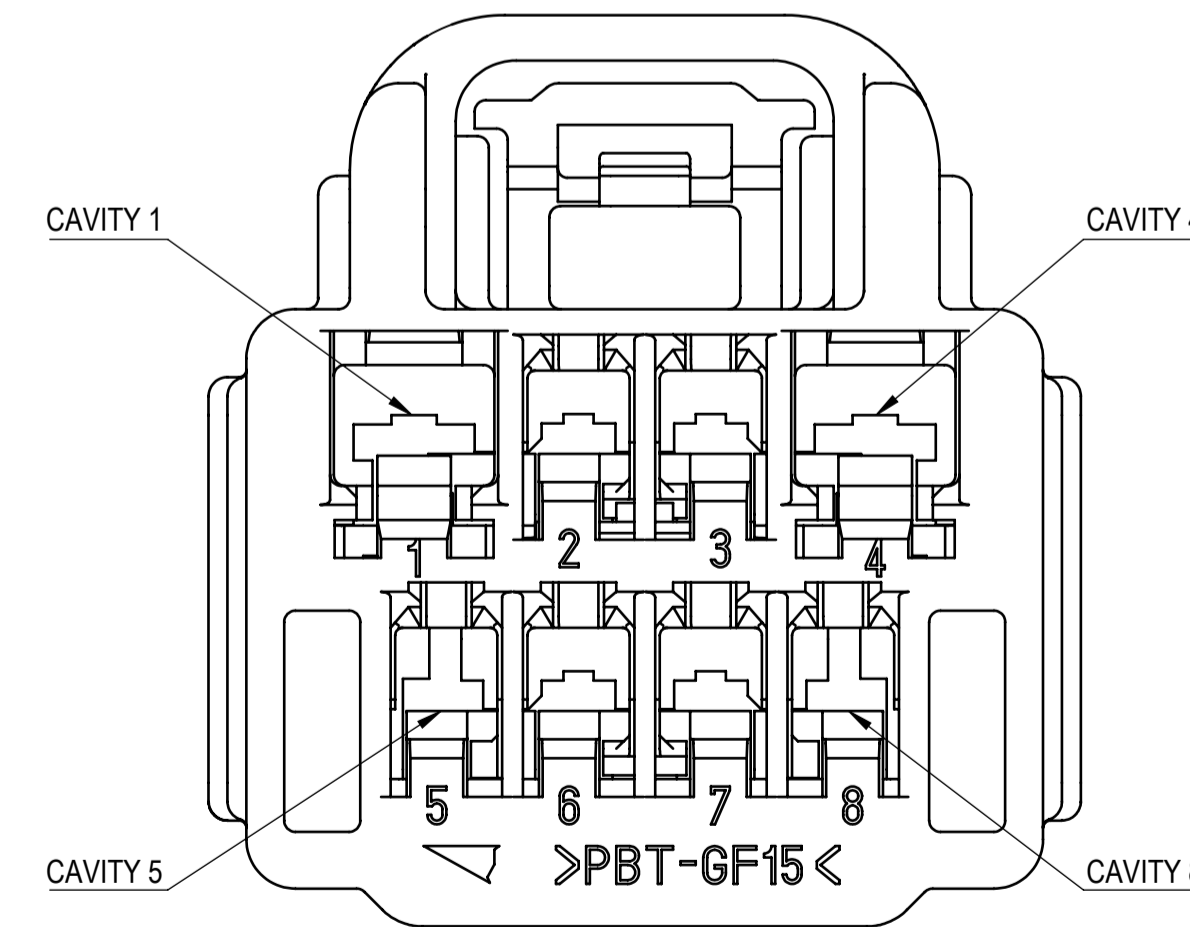
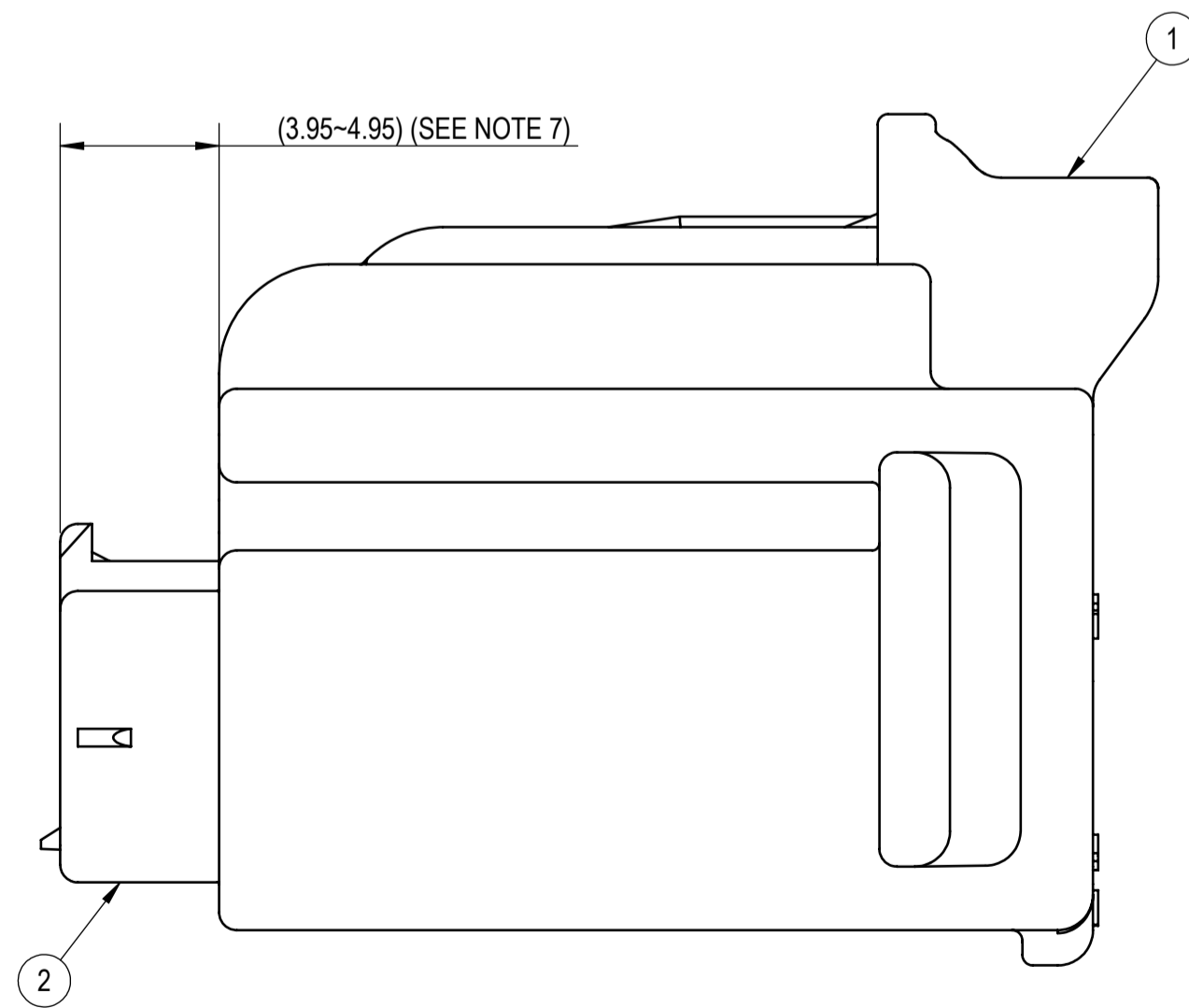
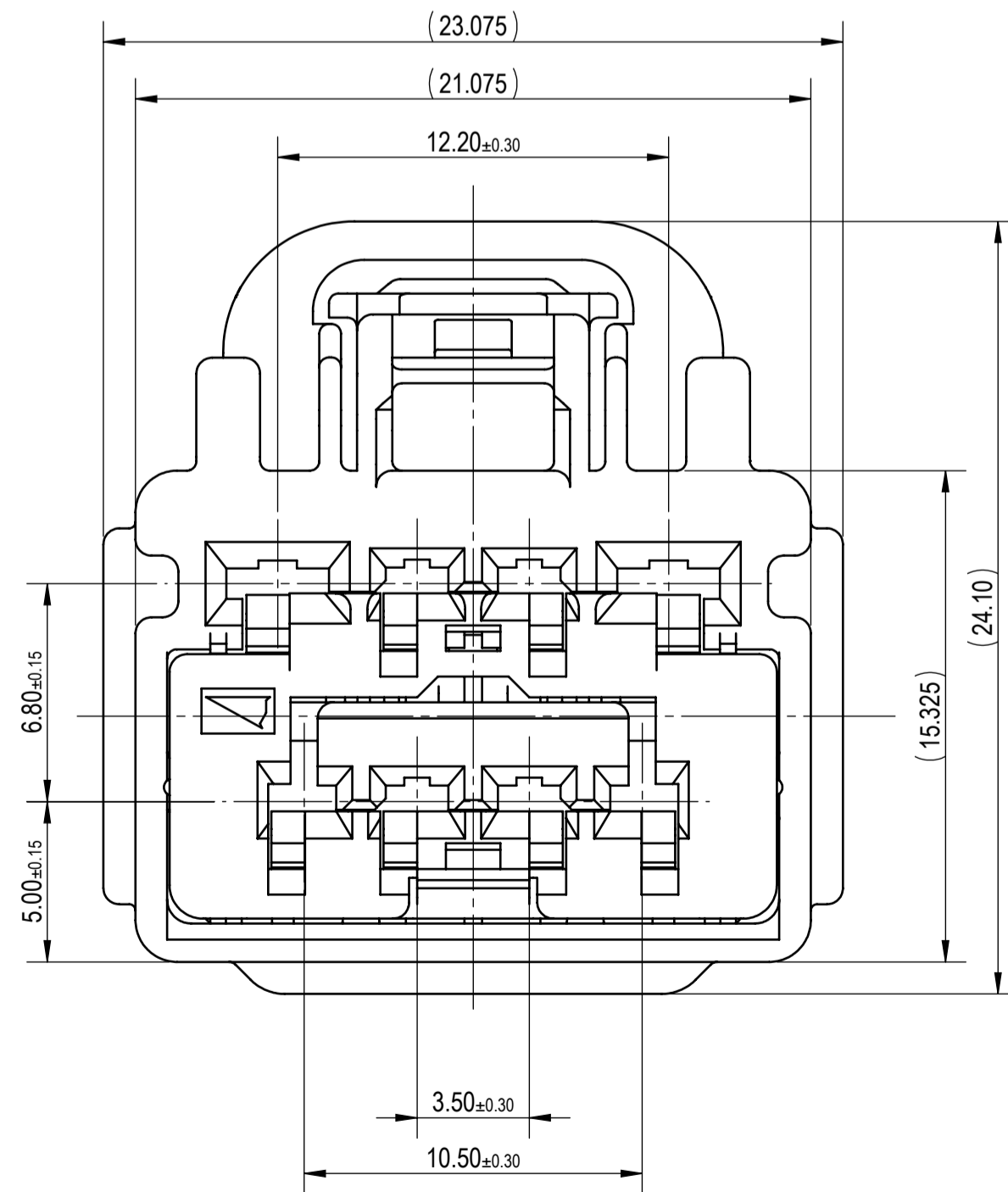
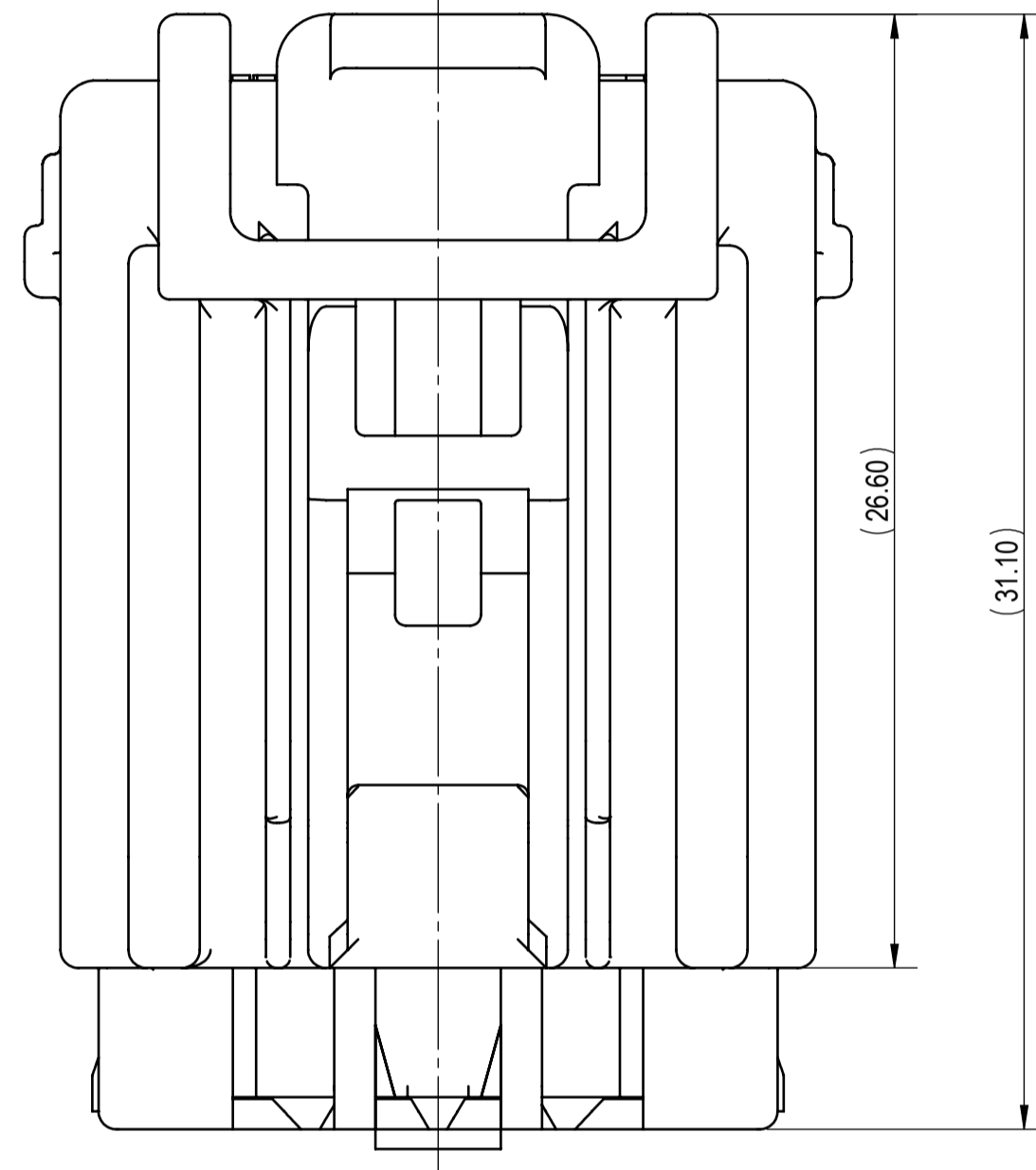

NOTES:

- PARTS MUST BE PURCHASED FROM YAZAKI.
- PARTS MUST BE FREE OF FLASH AND IMPERFECTIONS THAT AFFECT FUNCTION.
- APPLICABLE TERMINAL: SEE 7116-4780-02:R DRAWING (YESC KAIZEN 1.5 UNSEALED) OR MAX WIRE OD: 2.40mm (2, 3, 5-8 CAVITIES) SEE 7116-4100-02:R DRAWING (YESC 1.5 UNSEALED) MAX WIRE OD: 2.70mm (2, 3, 5-8 CAVITIES) SEE 7116-4270-02:R DRAWING (YESC KAIZEN 2.8 UNSEALED) OR MAX WIRE OD: 3.00mm (1, 4 CAVITIES) SEE 7116-4110-02:R DRAWING (YESC 2.8 UNSEALED) MAX WIRE OD: 3.70mm (1, 4 CAVITIES)
- MATING PART NUMBER: 7282-6448-40 OR EQUIVALENT.
- PART SATISFIES USCAR-2, REV.4, MAY 2004 (T2/V1/S1/MF3)
- PART TO COMPLY WITH YPES-31-038 REQUIREMENTS.
- THIS DIMENSION SHOWS THE PRE-SET POSITION OF THE TPA.
- THIS DRAWING IS TO BE USED FOR INTERNAL YAZAKI PSW SUBMISSION.
- HANDLING MANUAL NUMBER: YPES-15-599E

LET	DATE	REVISION RECORD	NO.	CHKD
-	05-09-2018	NEW	C18-A391	IM

GENERAL TOLERANCE											
A	±0.15	±0.20	±0.30	±0.50	±0.75	±0.20	±0.30	±0.50	±2.50	±3°	0.1
B	±0.20	±0.30	±0.55	±0.95	±1.40	±0.20	±0.30	±0.50	±2.50	±3°	0.1
C	±0.30	±0.50	±0.80	±1.40	±2.00	±0.20	±0.30	±0.50	±2.50	±3°	0.15
SPECIFIED										MASS	(7.50) g

CUSTOMER		MTRL SPEC.		TREAT. & FIN.	
CUSTOMER PART NO.	CUSTOMER DWG NO.	SEE TABLE	N/A		
OFFICE YNA	TRIAL PART NO.	NAME 8P (6Px1.5 + 2Px2.8) YESC KAIZEN UNSEALED			
VENDOR	VENDOR NO.	FEMALE CONNECTOR SUB-ASSEMBLY			
DWG TYPE R	DWG SOURCE 7287-0492-40:M	DWG DATE 05-09-2018	UNIT mm	SCL 5/1	ANGLE 3
APPROVED	CHECKED	CHECKED	DESIGN	DRAWN	PART NO. 7287-0492-40
			DESMOND ONG	ISABEL MUNIZ	CH. CODE
			04-07-2006	05-16-2018	DWG NO. 7287-0492-40:R
YAZAKI CORPORATION					

ISSUE MARK