

SUB ASSEMBLY PART NUMBER	NO.	PART NUMBER	PART NAME	MATERIAL	COLOR	QUANTITY	MASS (g)
7283-9016-30 [A]	①	7183-9010-30	4P 0.64 YESC KAIZEN UNSEALED FEMALE CONNECTOR HOUSING	PBT-GF15	BLACK	1	(2.33)
	②	7158-6580	4P 0.64 YESC KAIZEN UNSEALED FEMALE CONNECTOR FRONT HOLDER	PBT-GF15	NATURAL	1	
7289-5469-30	①	7183-9010-30	4P 0.64 YESC KAIZEN UNSEALED FEMALE CONNECTOR HOUSING	PBT-GF15	BLACK	1	(2.64)
	②	7158-6580	4P 0.64 YESC KAIZEN UNSEALED FEMALE CONNECTOR FRONT HOLDER	PBT-GF15	NATURAL	1	
	③	7172-1081-50	0.64 KAIZEN UNSEALED CONNECTOR CPA	PA66-GF35	RED	1	

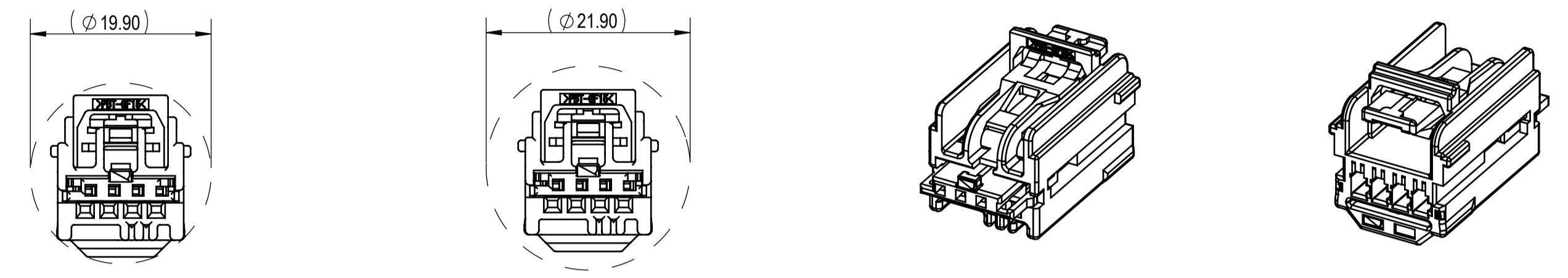

△ PASS-THROUGH HOLE DIMENSION CONNECTOR ONLY (NOMINAL) (2/1)
 △ RECOMMENDED PASS-THROUGH HOLE DIMENSION (1mm CLEARANCE ALL AROUND) (2/1)
 △ FRONT ISOMETRIC VIEW (2/1)
 △ REAR ISOMETRIC VIEW (2/1)

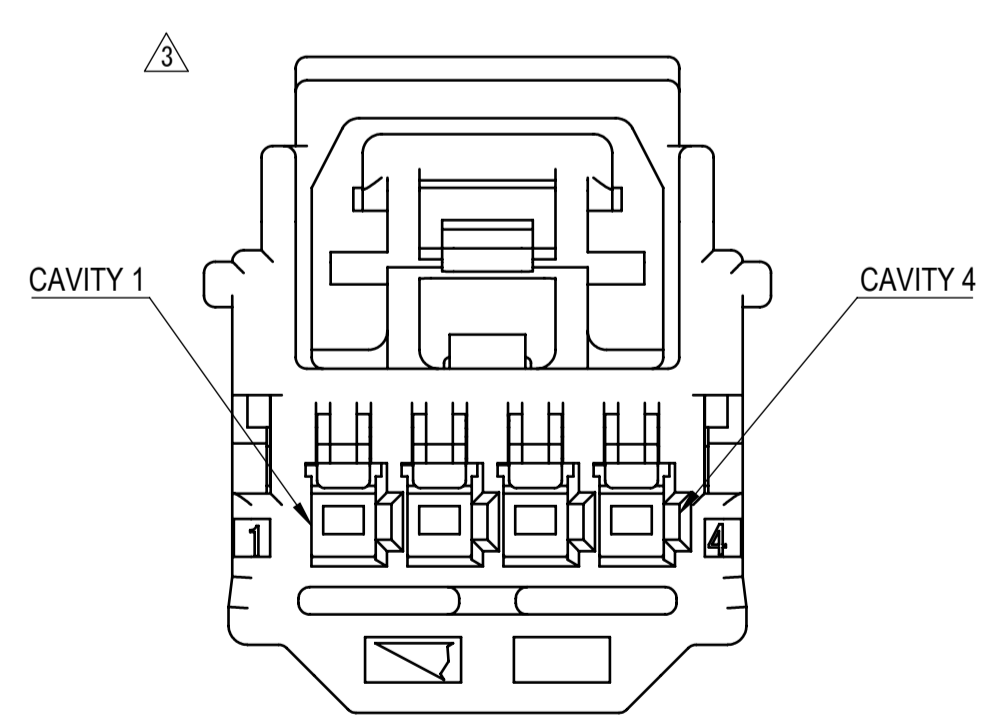
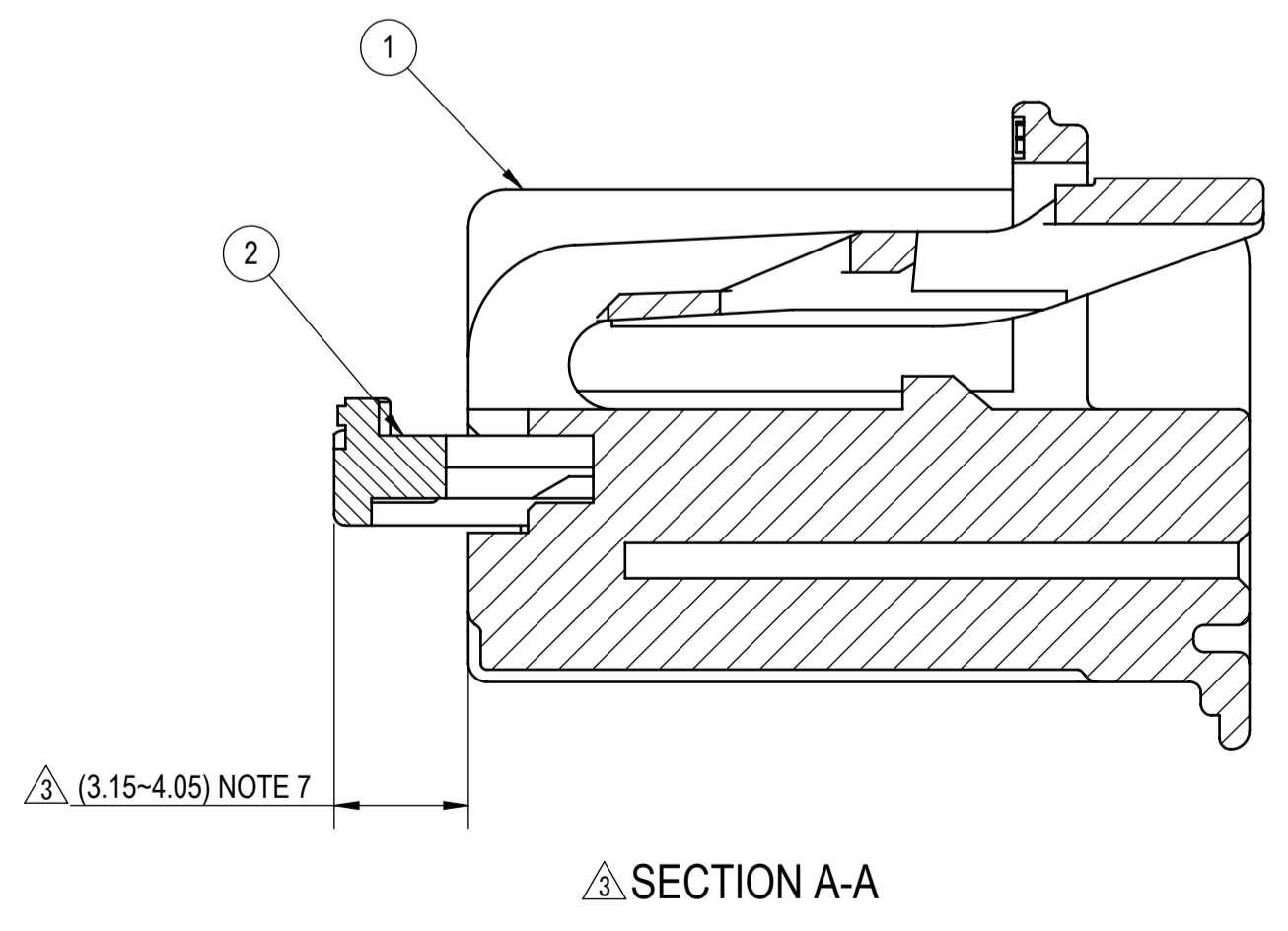
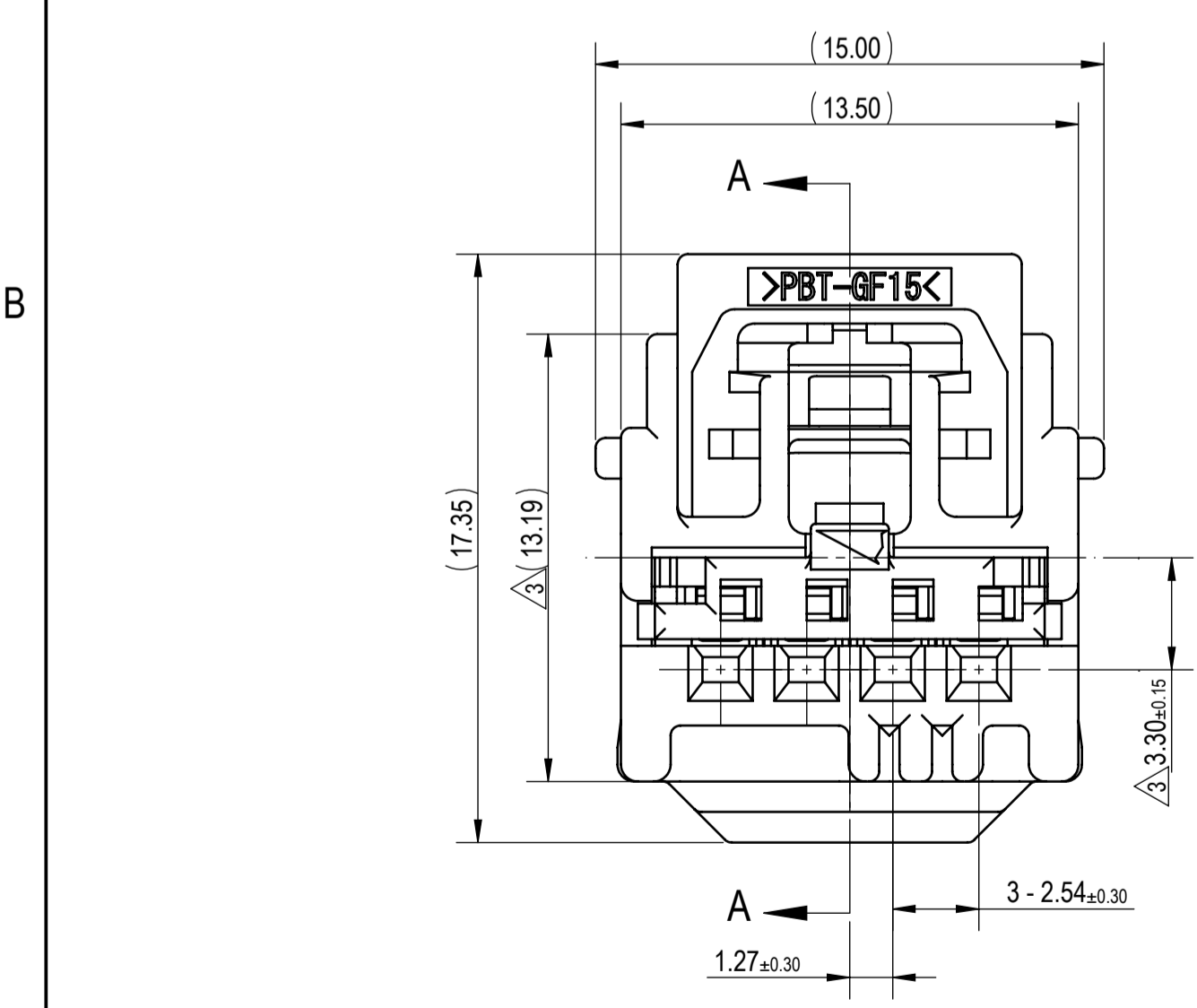
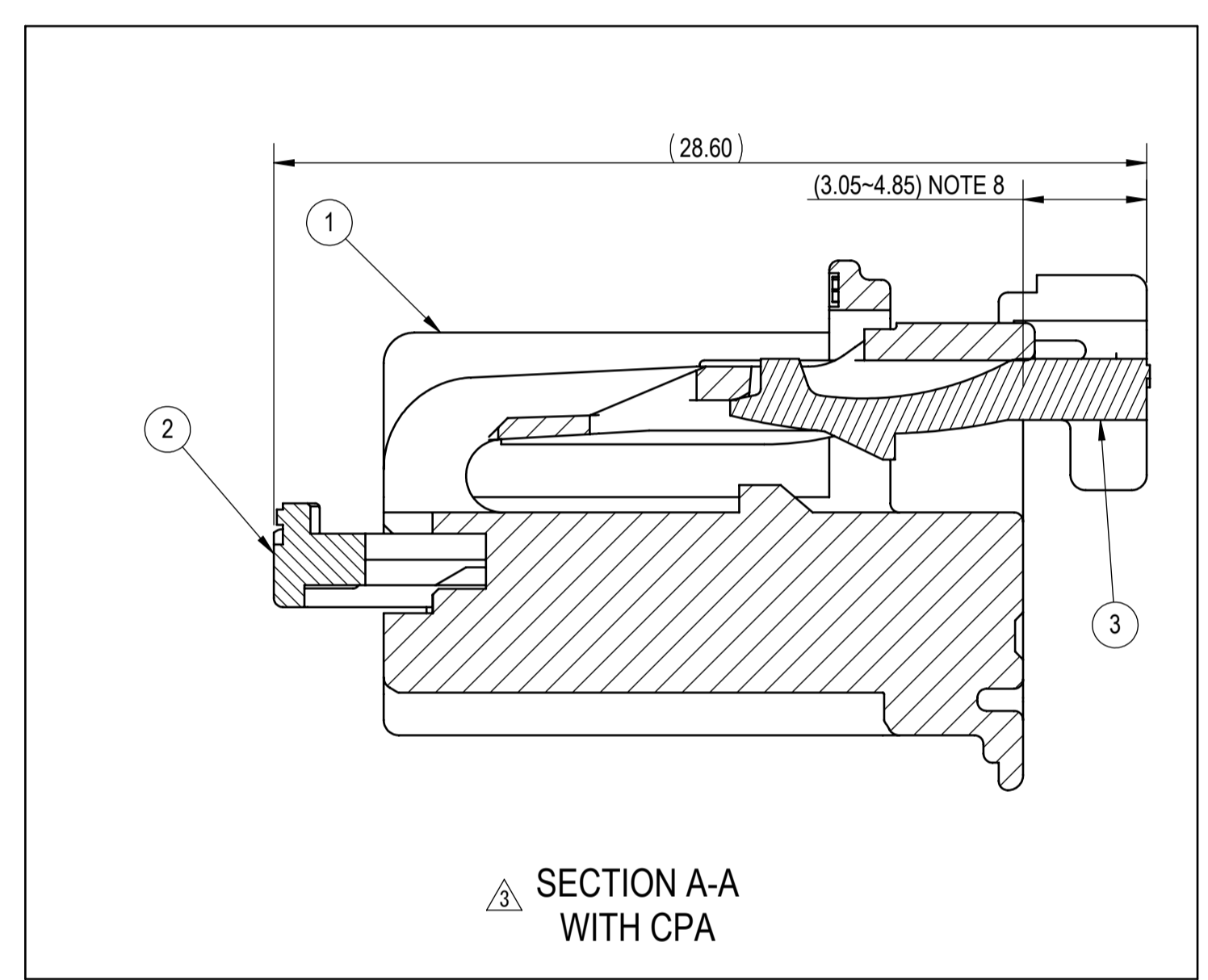
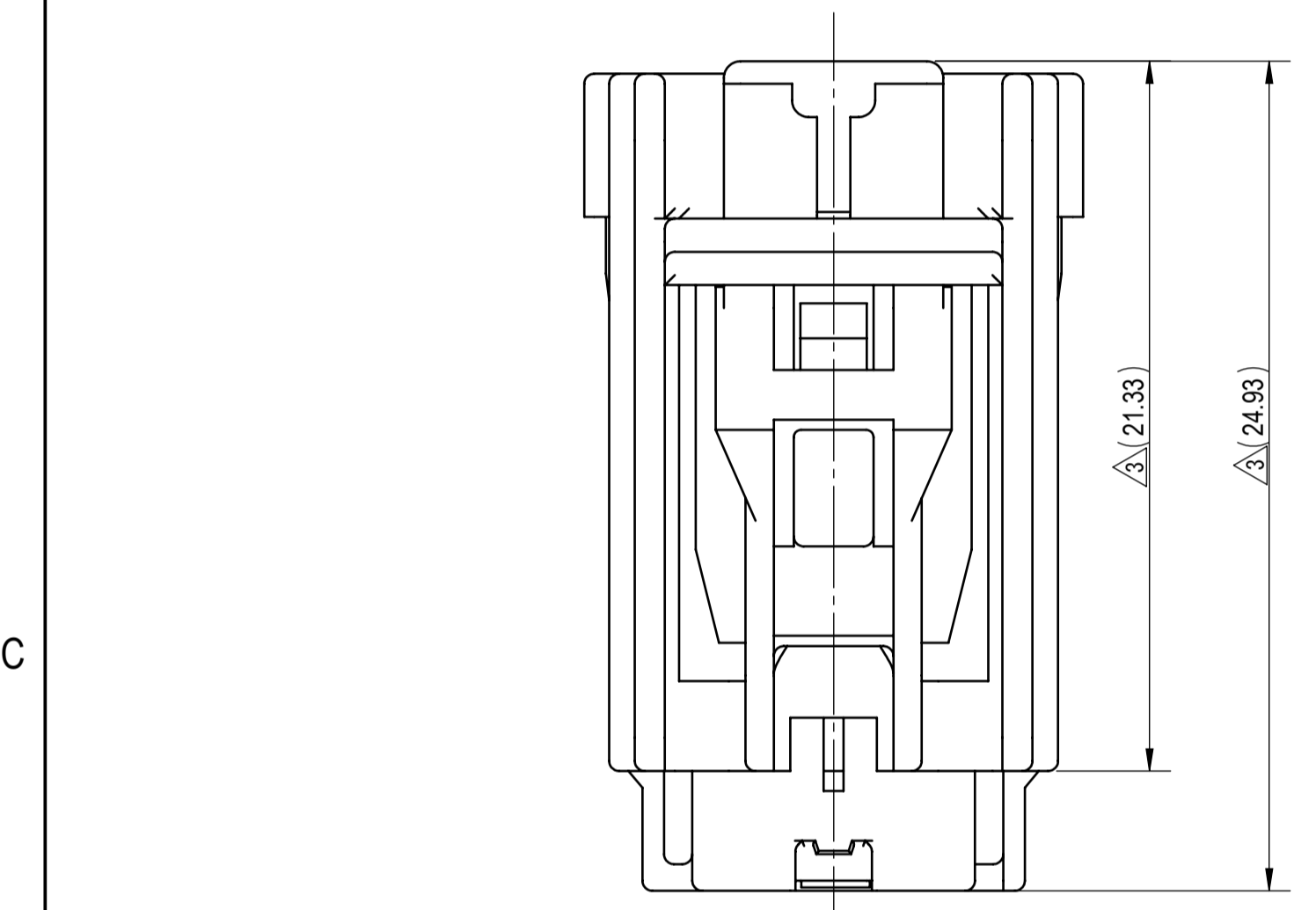

- △ NOTES:
- PARTS MUST BE PURCHASED FROM YAZAKI.
 - PARTS MUST BE FREE OF FLASH AND IMPERFECTIONS THAT AFFECT FUNCTION.
 - APPLICABLE TERMINAL: SEE 7116-4618-02:R DRAWING (0.64 KAIZEN) MAX WIRE OD: 1.90mm
 - PART DESIGNED TO MEET USCAR INTERFACE: 064-U-004-1-Z02
 - PART SATISFIES USCAR-2, REVISION 3, (TC2, SC1, VC1) WITH THE FOLLOWING EXCEPTIONS: 5.4.2 FORCE TO SERVICE = 7.20N MIN
 - PART TO COMPLY WITH YPES-31-038 REQUIREMENTS.
 - THIS DIMENSION SHOWS THE PRE-SET POSITION OF THE TPA.
 - THIS DIMENSION SHOWS THE PRE-SET POSITION OF THE CPA.
 - THIS DRAWING IS TO BE USED FOR INTERNAL YAZAKI PSW SUBMISSION.
 - HANDLING MANUAL NUMBER: YPES-15-711E.

DATE	REVISION RECORD	NO.	CHKD
07-11-2017	REDRAWN, ADDED VIEWS, ADDED PART NUMBER	C17-A728	I.M.
03-29-2011	ADDED VIEW	C11-Z226	Y.W.
10-15-2010	CHANGED PART NAME	C10-ZA72	N.B.
10-19-2006	NEW, [A]	C06-ZB43	T.Y.

GENERAL TOLERANCE											
	10MAX	50MAX	100MAX	250MAX	250OVR	R5 MAX	R10 MAX	R20 MAX	R20 OVR	ANGLE	ECCENT
A	±0.15	±0.20	±0.30	±0.50	±0.75					±3°	0.1
B	±0.20	±0.30	±0.55	±0.95	±1.40	±0.20	±0.30	±0.50	±2.50	±3°	0.15
③	±0.30	±0.50	±0.80	±1.40	±2.00						
MASS	SEE TABLE										

CUSTOMER		CUSTOMER DWG NO.		MATERIAL SPEC.		TREAT. & FIN.	
CUSTOMER PART NO.		CUSTOMER DWG NO.		SEE TABLE		N/A	
OFFICE YNA		TRIAL PART NO.		NAME △ 4P 0.64 YESC KAIZEN UNSEALED FEMALE CONNECTOR SUB-ASSEMBLY (1 ROW)			
VENDOR		VENDOR NO.		PART NO. 7283-9016-30, ETC. [A]			
				DWG NO. 7283-9016-30:R			
				YAZAKI CORPORATION			