

1	リチウムイオン	PBT	赤色
2	ケーブル	各種リコングム	黄色

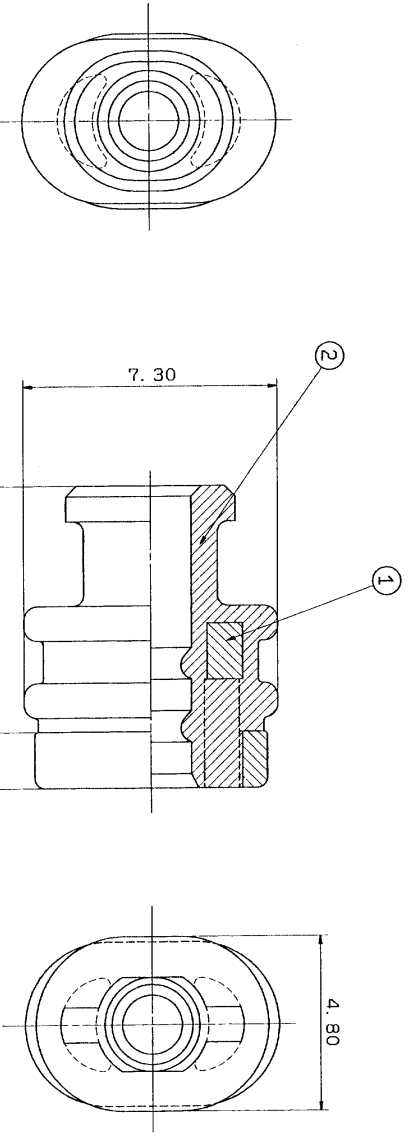

NOTES  
1) SUITABLE WIRE SIZE: AVSO. 5-AVO. 85

注記  
1) 適用電線サイズ: AVSO. 5-AVO. 85

LET	DATE	REVISED	BY	CHKD
	88.03.11		BMC-0304	
REVISION RECORD				
1				

10MAX	50MAX	100MAX	250MAX	250OVR	ANGLE	ECCENT
A ±0.15	±0.2	±0.3	±0.5	±0.75	±30°	0.1
⊙ ±0.2	±0.3	±0.55	±0.95	±1.4	±30°	0.1
C ±0.3	±0.5	±0.8	±1.4	±2	±30°	0.15
SPECIFIED						

CUSTOMER	CUSTOMER PART NO.	CUSTOMER DWG NO.
OFFICE		STDLIB NO.
VENDOR NO.		
DWG TYPE	DWG SOURCE	DWG DATE
4	87.03.02	M7M10/1
APPROVED	CHECKED	DRAWN
箱	箱	石
88.03.08	88.03.08	87.03.02

MATL. SPEC.	TREAT. & FIN.
DMSJX79	
14# (0.5, 0.85SQ#)	
PART NO. 7157-7933	TRIAL PART NO.
DWG NO. 7157-7933	
YAZAKI CORPORATION	

1 2 3 4 5