

RUBBER PART GENERAL TOLERANCE			
PART DIM.	1	2	3
0 TO 3	± 0.2	± 0.3	± 0.4
3 TO 6	± 0.2	± 0.4	± 0.5
6 TO 10	± 0.3	± 0.5	± 0.6
10 TO 18	± 0.3	± 0.6	± 0.8
18 TO 30	± 0.4	± 0.8	± 1.0
30 TO 50	± 0.5	± 1.0	± 1.5
50 TO 80	± 0.6	± 1.2	± 2.0
80 TO 120	± 0.7	± 1.4	± 2.5
120 TO 180	± 0.8	± 1.6	± 3.0
180 TO 250	± 1.0	± 2.0	± 4.0
250 TO 315	± 1.2	± 2.5	± 5.0
315 TO 400	± 1.5	± 3.0	± 6.0
400 TO 500	± 1.8	± 3.5	± 7.0
500 OVER	± 0.4 %	± 0.8 %	± 1.5 %

LET	DATE	REVISION RECORD	NO.	CHKD
△	93.12.08	CHANGED APPLICABLE WIRE SIZE RENEW AND ADD. SECTION AND CHANGED DRAWING	C93-7153	M. K.
△	89.07.12	REVISION RECORD	C89-L754	K. A.

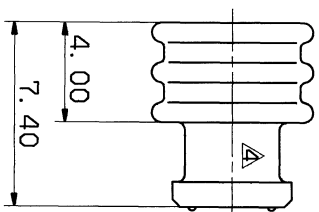
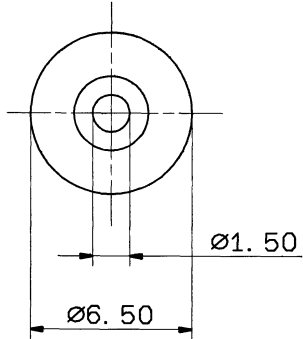

注 記
 1. 適用電線サイズ: CAVS 1.25 △
 AV 0.5 ~ 0.85 △
 AVS 0.5 ~ 1.25 △
 2. 適用端子品番: 7114-1232
 適用端子品番: 7116-1232

NOTES
 1. APPLICABLE WIRE SIZE: CAV 1.25 △
 AV 0.5 ~ 0.85 △
 AVS 0.5 ~ 1.25 △
 2. APPLICABLE TERMINAL MALE NO. : 7114-1232
 APPLICABLE TERMINAL FEMALE NO. : 7116-1232

10MAX	50MAX	100MAX	250MAX	500OVR	ANGLE	ECCENT
A ±0.15	±0.2	±0.3	±0.5	±0.75	±30°	0.1
B ±0.2	±0.3	±0.55	±0.95	±1.4	±30°	0.1
C ±0.3	±0.5	±0.8	±1.4	±2	±30°	0.15

GENERAL TOLERANCE 3

CUSTOMER	CUSTOMER PART NO.	CUSTOMER DWG NO.

OFFICE	STDLIB NO.	MATL. SPEC.	TREAT.
		SI RUBBER (BLACK)	& FIN.

NAME	W-TYPE	ISSUE MARK
RUBBER STOPPER FOR		

DWG NO.	PART NO.	TRIAL PART NO.
7157-3560:R	7157-3560	

APPROVED	CHECKED	DESIGN	DRAWN
<i>Shirai</i>	<i>H. SAKAI</i>	<i>甲斐</i>	

DATE	RENEW	CHECKED	DESIGN	DRAWN
83.12.21	83.06.17	<i>甲斐</i>	<i>H. SAKAI</i>	<i>甲斐</i>

DATE	RENEW	CHECKED	DESIGN	DRAWN
83.12.21	83.06.17	<i>甲斐</i>	<i>H. SAKAI</i>	<i>甲斐</i>

DATE	RENEW	CHECKED	DESIGN	DRAWN
83.12.21	83.06.17	<i>甲斐</i>	<i>H. SAKAI</i>	<i>甲斐</i>

DATE	RENEW	CHECKED	DESIGN	DRAWN
83.12.21	83.06.17	<i>甲斐</i>	<i>H. SAKAI</i>	<i>甲斐</i>

DATE	RENEW	CHECKED	DESIGN	DRAWN
83.12.21	83.06.17	<i>甲斐</i>	<i>H. SAKAI</i>	<i>甲斐</i>

DATE	RENEW	CHECKED	DESIGN	DRAWN
83.12.21	83.06.17	<i>甲斐</i>	<i>H. SAKAI</i>	<i>甲斐</i>

DATE	RENEW	CHECKED	DESIGN	DRAWN
83.12.21	83.06.17	<i>甲斐</i>	<i>H. SAKAI</i>	<i>甲斐</i>

DATE	RENEW	CHECKED	DESIGN	DRAWN
83.12.21	83.06.17	<i>甲斐</i>	<i>H. SAKAI</i>	<i>甲斐</i>

DATE	RENEW	CHECKED	DESIGN	DRAWN
83.12.21	83.06.17	<i>甲斐</i>	<i>H. SAKAI</i>	<i>甲斐</i>

DATE	RENEW	CHECKED	DESIGN	DRAWN
83.12.21	83.06.17	<i>甲斐</i>	<i>H. SAKAI</i>	<i>甲斐</i>

DATE	RENEW	CHECKED	DESIGN	DRAWN
83.12.21	83.06.17	<i>甲斐</i>	<i>H. SAKAI</i>	<i>甲斐</i>

DATE	RENEW	CHECKED	DESIGN	DRAWN
83.12.21	83.06.17	<i>甲斐</i>	<i>H. SAKAI</i>	<i>甲斐</i>

DATE	RENEW	CHECKED	DESIGN	DRAWN
83.12.21	83.06.17	<i>甲斐</i>	<i>H. SAKAI</i>	<i>甲斐</i>

DATE	RENEW	CHECKED	DESIGN	DRAWN
83.12.21	83.06.17	<i>甲斐</i>	<i>H. SAKAI</i>	<i>甲斐</i>

DATE	RENEW	CHECKED	DESIGN	DRAWN
83.12.21	83.06.17	<i>甲斐</i>	<i>H. SAKAI</i>	<i>甲斐</i>

DATE	RENEW	CHECKED	DESIGN	DRAWN
83.12.21	83.06.17	<i>甲斐</i>	<i>H. SAKAI</i>	<i>甲斐</i>

DATE	RENEW	CHECKED	DESIGN	DRAWN
83.12.21	83.06.17	<i>甲斐</i>	<i>H. SAKAI</i>	<i>甲斐</i>

DATE	RENEW	CHECKED	DESIGN	DRAWN
83.12.21	83.06.17	<i>甲斐</i>	<i>H. SAKAI</i>	<i>甲斐</i>

DATE	RENEW	CHECKED	DESIGN	DRAWN
83.12.21	83.06.17	<i>甲斐</i>	<i>H. SAKAI</i>	<i>甲斐</i>

DATE	RENEW	CHECKED	DESIGN	DRAWN
83.12.21	83.06.17	<i>甲斐</i>	<i>H. SAKAI</i>	<i>甲斐</i>

DATE	RENEW	CHECKED	DESIGN	DRAWN
83.12.21	83.06.17	<i>甲斐</i>	<i>H. SAKAI</i>	<i>甲斐</i>

DATE	RENEW	CHECKED	DESIGN	DRAWN
83.12.21	83.06.17	<i>甲斐</i>	<i>H. SAKAI</i>	<i>甲斐</i>

DATE	RENEW	CHECKED	DESIGN	DRAWN
83.12.21	83.06.17	<i>甲斐</i>	<i>H. SAKAI</i>	<i>甲斐</i>

DATE	RENEW	CHECKED	DESIGN	DRAWN
83.12.21	83.06.17	<i>甲斐</i>	<i>H. SAKAI</i>	<i>甲斐</i>

DATE	RENEW	CHECKED	DESIGN	DRAWN
83.12.21	83.06.17	<i>甲斐</i>	<i>H. SAKAI</i>	<i>甲斐</i>

DATE	RENEW	CHECKED	DESIGN	DRAWN
83.12.21	83.06.17	<i>甲斐</i>	<i>H. SAKAI</i>	<i>甲斐</i>

DATE	RENEW	CHECKED	DESIGN	DRAWN
83.12.21	83.06.17	<i>甲斐</i>	<i>H. SAKAI</i>	<i>甲斐</i>

DATE	RENEW	CHECKED	DESIGN	DRAWN
83.12.21	83.06.17	<i>甲斐</i>	<i>H. SAKAI</i>	<i>甲斐</i>

DATE	RENEW	CHECKED	DESIGN	DRAWN
83.12.21	83.06.17	<i>甲斐</i>	<i>H. SAKAI</i>	<i>甲斐</i>

DATE	RENEW	CHECKED	DESIGN	DRAWN
83.12.21	83.06.17	<i>甲斐</i>	<i>H. SAKAI</i>	<i>甲斐</i>

DATE	RENEW	CHECKED	DESIGN	DRAWN
83.12.21	83.06.17	<i>甲斐</i>	<i>H. SAKAI</i>	<i>甲斐</i>

DATE	RENEW	CHECKED	DESIGN	DRAWN
83.12.21	83.06.17	<i>甲斐</i>	<i>H. SAKAI</i>	<i>甲斐</i>

DATE	RENEW	CHECKED	DESIGN	DRAWN
83.12.21	83.06.17	<i>甲斐</i>	<i>H. SAKAI</i>	<i>甲斐</i>

DATE	RENEW	CHECKED	DESIGN	DRAWN
83.12.21	83.06.17	<i>甲斐</i>	<i>H. SAKAI</i>	<i>甲斐</i>

DATE	RENEW	CHECKED	DESIGN	DRAWN
83.12.21	83.06.17	<i>甲斐</i>	<i>H. SAKAI</i>	<i>甲斐</i>

DATE	RENEW	CHECKED	DESIGN	DRAWN
83.12.21	83.06.17	<i>甲斐</i>	<i>H. SAKAI</i>	<i>甲斐</i>

DATE	RENEW	CHECKED	DESIGN	DRAWN
83.12.21	83.06.17	<i>甲斐</i>	<i>H. SAKAI</i>	<i>甲斐</i>

DATE	RENEW	CHECKED	DESIGN	DRAWN
83.12.21	83.06.17	<i>甲斐</i>	<i>H. SAKAI</i>	<i>甲斐</i>

DATE	RENEW	CHECKED	DESIGN	DRAWN
83.12.21	83.06.17	<i>甲斐</i>	<i>H. SAKAI</i>	<i>甲斐</i>

DATE	RENEW	CHECKED	DESIGN	DRAWN
83.12.21	83.06.17	<i>甲斐</i>	<i>H. SAKAI</i>	<i>甲斐</i>

DATE	RENEW	CHECKED	DESIGN	DRAWN
83.12.21	83.06.17	<i>甲斐</i>	<i>H. SAKAI</i>	<i>甲斐</i>

DATE	RENEW	CHECKED	DESIGN	DRAWN
83.12.21	83.06.17	<i>甲斐</i>	<i>H. SAKAI</i>	<i>甲斐</i>

DATE	RENEW	CHECKED	DESIGN	DRAWN
83.12.21	83.06.17	<i>甲斐</i>	<i>H. SAKAI</i>	<i>甲斐</i>

DATE	RENEW	CHECKED	DESIGN	DRAWN
83.12.21	83.06.17	<i>甲斐</i>	<i>H. SAKAI</i>	<i>甲斐</i>

DATE	RENEW	CHECKED	DESIGN	DRAWN
83.12.21	83.06.17	<i>甲斐</i>	<i>H. SAKAI</i>	<i>甲斐</i>

DATE	RENEW	CHECKED	DESIGN	DRAWN
83.12.21	83.06.17	<i>甲斐</i>	<i>H. SAKAI</i>	<i>甲斐</i>

DATE	RENEW	CHECKED	DESIGN	DRAWN
83.12.21	83.06.17	<i>甲斐</i>	<i>H. SAKAI</i>	<i>甲斐</i>

DATE	RENEW	CHECKED	DESIGN	DRAWN
83.12.21	83.06.17	<i>甲斐</i>	<i>H. SAKAI</i>	<i>甲斐</i>

DATE	RENEW	CHECKED	DESIGN	DRAWN
83.12.21	83.06.17	<i>甲斐</i>	<i>H. SAKAI</i>	<i>甲斐</i>

DATE	RENEW	CHECKED	DESIGN	DRAWN
83.12.21	83.06.17	<i>甲斐</i>	<i>H. SAKAI</i>	<i>甲斐</i>

DATE	RENEW	CHECKED	DESIGN	DRAWN
83.12.21	83.06.17	<i>甲斐</i>	<i>H. SAKAI</i>	<i>甲斐</i>

DATE	RENEW	CHECKED	DESIGN	DRAWN
83.12.21	83.06.17	<i>甲斐</i>	<i>H. SAKAI</i>	<i>甲斐</i>

DATE	RENEW	CHECKED	DESIGN	DRAWN
83.12.21	83.06.17	<i>甲斐</i>	<i>H. SAKAI</i>	<i>甲斐</i>

DATE	RENEW	CHECKED	DESIGN	DRAWN
83.12.21	83.06.17	<i>甲斐</i>	<i>H. SAKAI</i>	<i>甲斐</i>

DATE	RENEW	CHECKED	DESIGN	DRAWN
83.12.21	83.06.17	<i>甲斐</i>	<i>H. SAKAI</i>	<i>甲斐</i>

DATE	RENEW	CHECKED	DESIGN	DRAWN
83.12.21	83.06.17	<i>甲斐</i>	<i>H. SAKAI</i>	<i>甲斐</i>

DATE	RENEW	CHECKED	DESIGN	DRAWN
83.12.21	83.06.17	<i>甲斐</i>	<i>H. SAKAI</i>	<i>甲斐</i>

DATE	RENEW	CHECKED	DESIGN	DRAWN
83.12.21	83.06.17	<i>甲斐</i>	<i>H. SAKAI</i>	<i>甲斐</i>