

1

2

3



符 号	矢 崎 品 番	色
C06MW	7122-7860	自 然 色
C06MW-Y	△ (7B22-7860-70)注 3) 7122-7860-70	黄 色

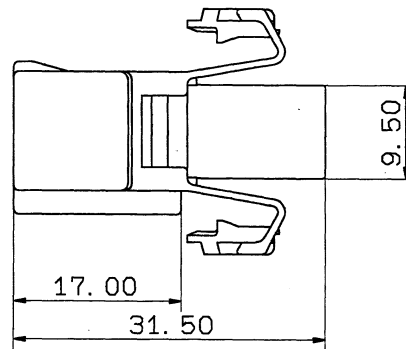
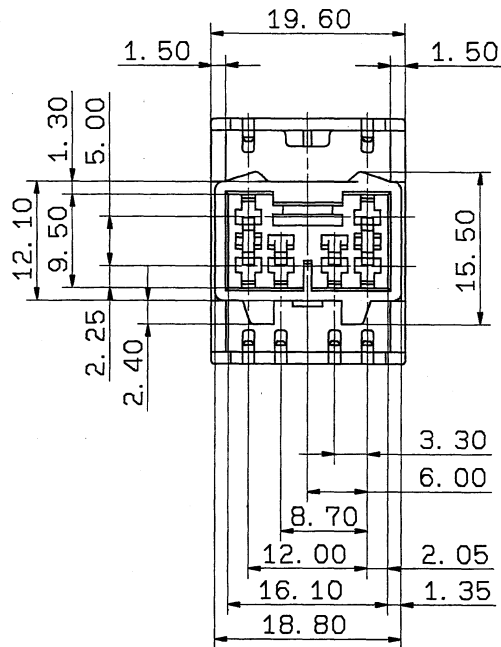
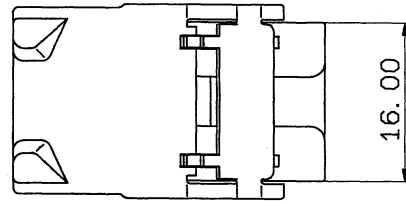

NOTES

- 1) MATING HOUSING NO. :7123-7860 etc.
- 2) MATING TERMINAL NO. :7114-1300 etc.
- △ 3) ( ) PART NO. TO BE USED AIR-BAG SYSTEM AND ADMINISTRATION SYSTEM.

注 記

- 1) 嵌合相手品番:7123-7860 etc.
- 2) 使用端子品番:7114-1300 etc.
- △ 3) ( ) 内品番は、エアバック回路及び特別管理回路で使用する場合に適用すること。

ISSUE MARK

△ 88.12.16	品番変更	BMC-1782	K. A	CUSTOMER		MATL. PBT	TREAT. & FIN.
△ 88.12.09	品番追加	BMC-1724	H. Y	CUSTOMER PART NO.	CUSTOMER DWG NO.		
— 88.09.23	新設	BMC-1196	K. A	CO6MW, C06MW-Y		NAME	C-TYPE CONNECTOR HOUSING
LET	DATE	REVISION RECORD	NO.	CHKD	VENDOR		
GENERAL TOLERANCE				VENDOR NO.			
	10MAX	50MAX	100MAX	250MAX	250OVR	ANGLE	ECCENT
A	±0.15	±0.2	±0.3	±0.5	±0.75	±30'	0.1
B	±0.2	±0.3	±0.55	±0.95	±1.4	±30'	0.1
◎	±0.3	±0.5	±0.8	±1.4	±2	±30'	0.15
SPECIFIED				WEIGHT			
				g			
				88.12.16			
				APPROVED			
				CHECKED			
				CHECKED			
				DESIGN			
				DRAWN			
				DWG NO.			
				7122-7860-R			
				TRIAL PART NO.			
				YAZAKI CORPORATION			

1

2

3

